



BT 300

Direct In-car Battery Tester

FEATURES

Standard Features :

- Checking the battery charge power status
- Direct 12V cigarette socket plug-in
- LED indicator for easy reading of essential information

Packaging information			
Gift Box Size:	220x217x45mm		
Outer Carton:	575x490x165mm		
QTN/CTN:	40PCS		
N.W.:	2.0kgs	G.W.:	3.2kgs
20" Container	25120pcs		
40" Container	50560pcs		



DIMENSIONS

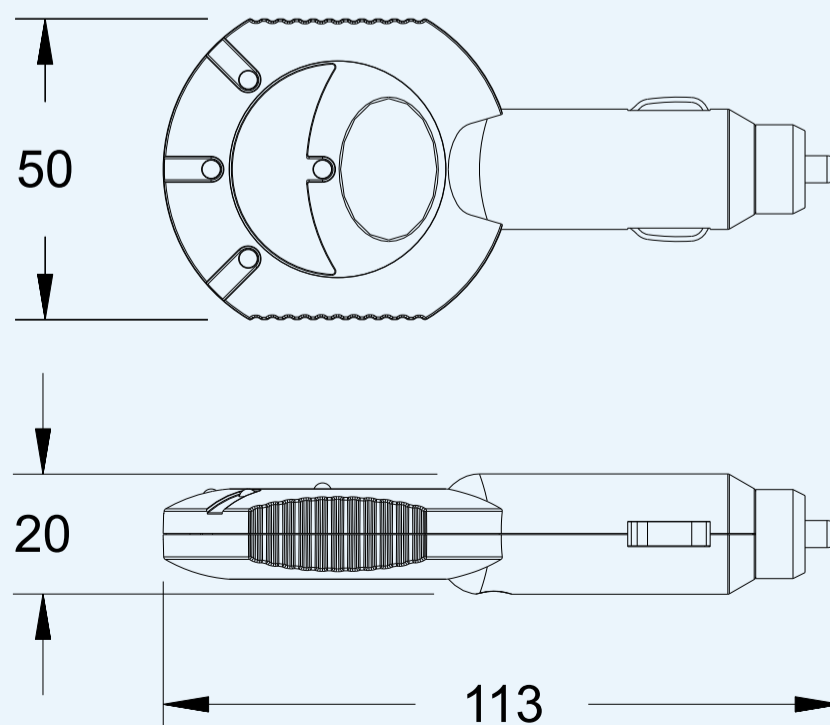

SPECIFICATIONS ARE SUBJECT TO CHANGE WITHOUT PRIOR NOTICE